

TE-6800 Series Temperature Sensors

Installation Instructions

TE-68xx-xN00S

Part No. 24-10409-1, Rev. D

Issued July 21, 2010

Supersedes May 4, 2010

Applications

The TE-68xx-xN00S Series provides temperature sensing in room wall mount applications. It allows local setpoint temperature adjustment and temporary occupancy override.

A warmer/cooler dial is included on certain models for minor temperature adjustments from the setpoint. An occupancy override button allows the user to request a time-of-day scheduling override when the space is occupied outside of the normal occupied hours schedule. All sensors have DIP switches that enable or disable unit functions.

Depending on the model chosen, the wires connecting the sensor to the controller can be terminated using a screw terminal block or modular jack connection, offering wiring flexibility. All models include a Zone Bus access port for connecting accessories to access the 6-pin modular jack. This feature allows a technician to commission or service the controller via the sensor.

IMPORTANT: Use the TE-6800 Series Temperature Sensor only to provide input to equipment under normal operating conditions. Where failure or malfunction of the TE-6800 Series element could lead to personal injury or property damage to the controlled equipment or other property, additional precautions must be designed into the control system. Incorporate and maintain other devices, such as supervisory or alarm systems or safety or limit controls, intended to warn of or protect against failure or malfunction of the TE-6800 Series.

Installation

Special Tools Needed

A 1/16 in. (1.5 mm) hex wrench or a Johnson Controls® T-4000-119 hex-head adjustment tool is required during installation.

Accessories

To install the TE-6800 Series Temperature Sensor on a wallbox requires accessory NS-WALLPLATE-0, ordered separately.

Mounting

Location Considerations

Locate the TE-6800 sensor:

- on a partitioning interior wall, and approximately 5 ft (1.5 m) above the floor in a location of average temperature
- away from direct sunlight, radiant heat, outside walls, behind doors, air discharge grills, stairwells, or outside doors
- away from steam or water pipes, warm air stacks, unconditioned areas (no heating and no cooling), or sources of electrical interference

Note: The TE-6800 Series sensor is shock and vibration resistant; however, be careful not to drop the unit or mount it where it could be exposed to excessive vibration.

The following ambient operating conditions apply:

- Temperature: 32 to 131°F (0 to 55°C)
- Humidity: 10 to 95% Relative Humidity (RH), noncondensing; 86°F (30°C) maximum dew point

To mount the sensor to the wall:

1. Use a 1/16 in. (1.5 mm) hex wrench or Johnson Controls T-4000-119 hex-head adjustment tool to loosen the security screw on the top of the unit.
2. Insert a blade screwdriver into the slot next to the security screw location, and then carefully pry the top edge of the sensor assembly away from its mounting base and remove.

IMPORTANT: Do not remove the Printed Circuit Board (PCB). Removing the PCB voids the product warranty.

3. Pull out approximately 6 in. (152 mm) of cable from the wall, and insert the cable through the hole in the mounting base.
4. Align the mounting base on the wall, and use the base as a template to mark the location of the two mounting holes on the surface.

Note: Confirm that the mounting base is positioned with the proper edge up. The mounting base is positioned properly when the security screw is located on the top edge of the base.

5. Secure the mounting base to the wall using the appropriate mounting hardware (field furnished).
6. Set DIP switches for the desired operation. See *Setup and Adjustments* and *Internal Wiring Diagrams* for additional information.

For models featuring a screw terminal block, wire the unit as illustrated in Figure 4.

7. Align the tabs on the bottom edge of the mounting base with the slots on the bottom edge of the sensor assembly, and rotate the assembly onto its mounting base.

Note: On models featuring a screw terminal block, be certain that the terminal block pins align with the holes in the terminal block.

8. Use a 1/16 in. (1.5 mm) hex wrench or Johnson Controls T-4000-119 hex-head Adjustment Tool to tighten the security screw and fasten the network sensor assembly to the mounting base.

Wiring



CAUTION: Risk of Property Damage.

Do not apply power to the system before checking all wiring connections. Short circuited or improperly connected wires may result in permanent damage to the equipment.

IMPORTANT: Use copper conductors only. Make all wiring connections in accordance with local, national, and regional regulations.

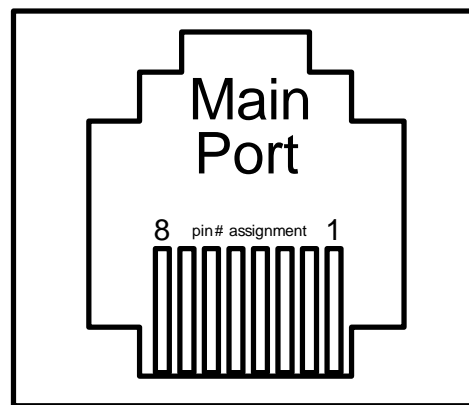

Figure 1: Modular Jack Pin Number Assignments

Keep wires as short as possible to minimize sensor error. Each 250 ft (76 m) run of 18 AWG wire or 50 ft (15 m) of 24 AWG wire creates 1F° (0.56C°) error for a nickel sensor or 1.5F° (0.83C°) error for a platinum sensor due to wire resistance. To maintain less than 1F° (0.56C°) error for nickel or 1.5F° (0.83C°) error for platinum, hold the total resistance of all sensor wiring below 3 ohms. When wiring the TE-6800, do not run low voltage wiring in the same conduit as line voltage wiring or other conductors supplying highly inductive loads.

Internal Wiring Diagrams

Internal wiring diagrams are shown in Figure 2 and Figure 3. Terminal block designations are shown in Figure 4. The terminals are identified in Table 1. See the *Setup and Adjustments* section and Figure 5 for an explanation of the Light-Emitting Diode (LED) and Push Button (PB) modes. Make connections pairing the following wires:

- sensor (Terminal 1 and Terminal 2)
- setpoint (Terminal 3 and Terminal 4)
- Zone Bus and Common (COM) (Terminals 6 and 7)

Shielding is not required. If used, follow the system controller's recommendations for grounding the shield.

Note: The Manual Override PB does not respond when the DIP switch positions are all down (LED mode NO PB, as shown in Figure 3 and Figure 5).

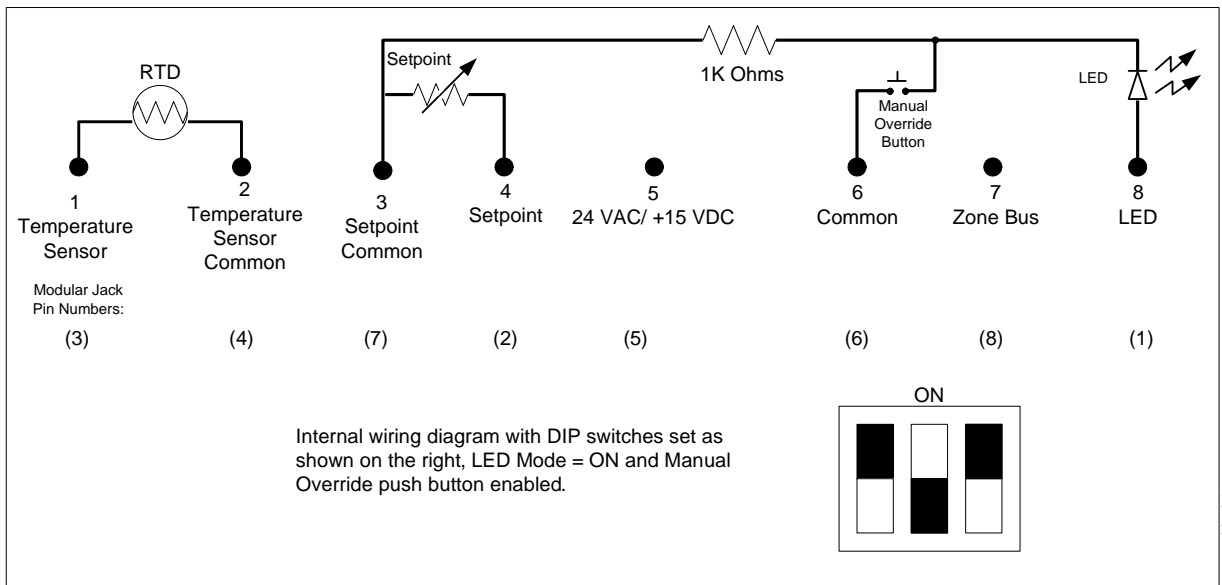

term_block1

Figure 2: Terminal Block Wiring Designations (LED ON Mode [Factory Default] and Manual Override PB Enabled)

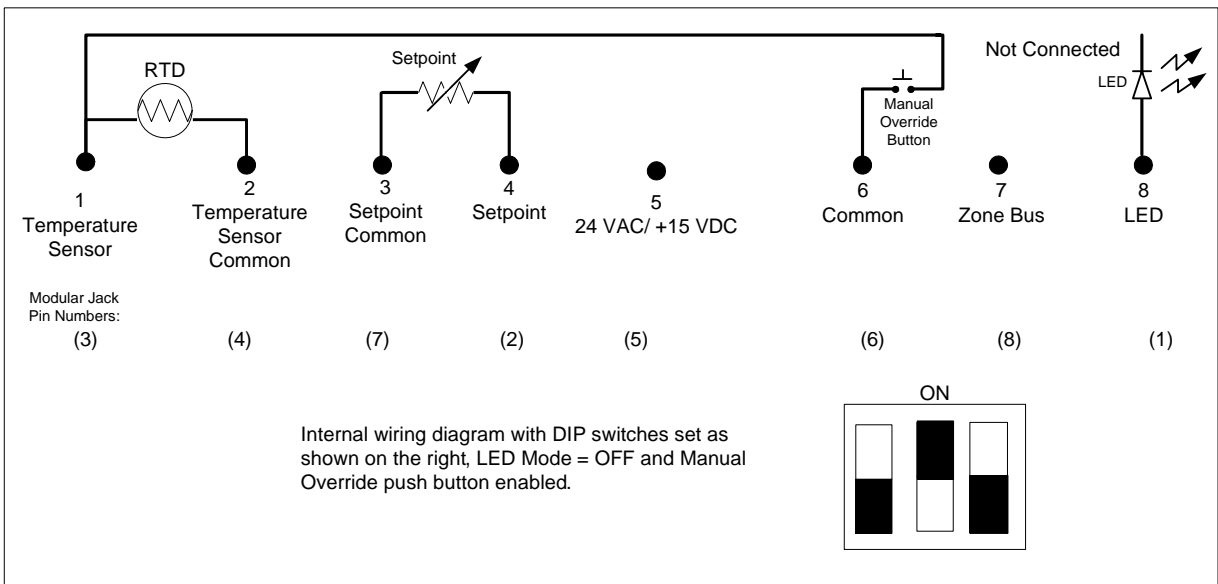

term_bloc2

Figure 3: Terminal Block Wiring Designations (LED OFF Mode and Manual Override PB Enabled)

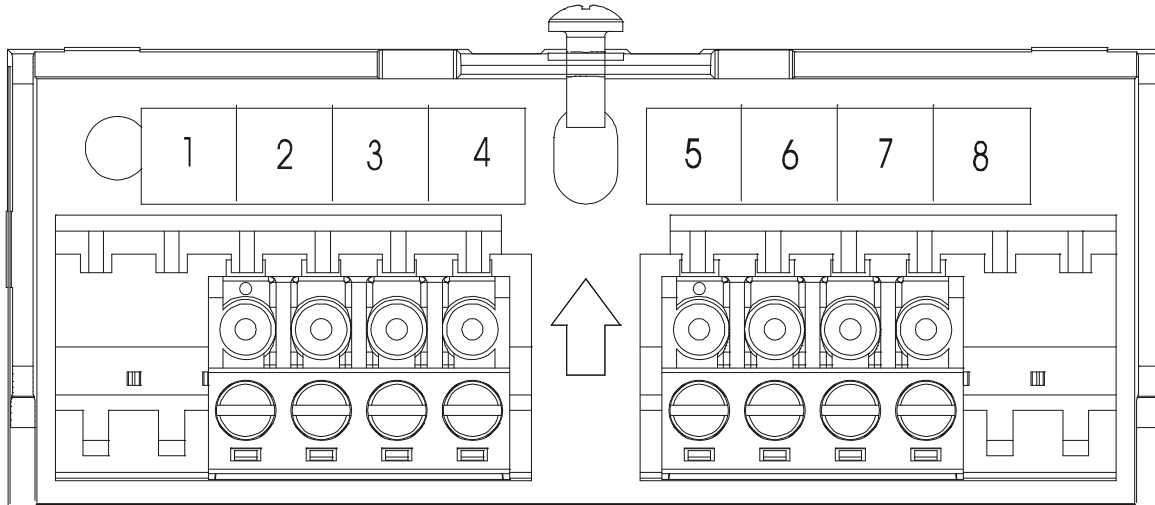

Figure 4: Terminal Block Location and Wiring

Table 1: Terminal Block Wiring

Terminal	Signal Designation
1	Temperature Sensor and Manual Override
2	Temperature Sensor Common
3	Setpoint Common and LED Common
4	Setpoint
5	24 VAC (+15 VDC - VMA only) ¹
6	Common (for Power, Zone Bus, or Manual Override)
7	Zone Bus
8	LED and Manual Override

1. The +15 VDC power supply is used only when a TE-6800 Series sensor is connected to a Variable Air Volume Modular Assembly (VMA) controller.

Note: Manual Override is selected for either Terminals 1 and 6 to short sensor (with DIP switch set for LED Off) or Terminal 6 and Terminal 8 to short LED (with DIP switch set for LED On).

Modular Jack Wiring (TE-68xP Models)

The modular jack connection is shown in Figure 1. Make modular jack electrical connections to the 8-pin RJ45 connector, using 8 conductor standard or plenum-rated telephone cables. Terminals are identified in Table 2. Insert the modular jack connector with the proper polarity (not reversed). Misalignment can cause damage. Refer to the controller documentation to determine the appropriate cable assembly.

IMPORTANT: Do not insert a 6-pin connector or anything other than an RJ-45 8-pin connector into the 8-pin jack on the back of the TE-6800 Temperature Sensor to prevent damaging the modular jack.

Table 2: Modular Jack Pin Designations

Modular Jack Pin Number	Signal Designation
1	LED and Manual Override
2	Setpoint
3	Temperature Sensor and Manual Override
4	Temperature Sensor Common
5	24 VAC (+15 VDC - VMA only) ¹
6	Common (for Power, Zone Bus, or Manual Override)
7	Setpoint Common
8	Zone Bus

1. The +15 VDC power supply is used only when a TE-6800 Series sensor is connected to a VMA controller.

Setup and Adjustments

Controller Configuration Switch

A DIP switch configures the TE-6800 for use with the desired controller by enabling or disabling the manual override PB and the LED, in appropriate models.

To change the controller mode, use the three position DIP switch located on the Printed Circuit Board (PCB). See Figure 5 and consult Table 3 to determine controller compatibility.



CAUTION: Risk of Property Damage.
Do not use switch settings other than those shown in Figure 5. Using other switch settings may cause incorrect controller operation or damage to the element, controller, and/or controlled equipment.

Warmer/Cooler Setpoint and No Setpoint Models

For the Warmer/Cooler Setpoint and No Setpoint models, the factory default is the **LED Mode:ON** described as follows. The switch positions enable/disable the following functions:

LED Mode: OFF (LED Disabled, but Sensor and PB Enabled) Switch positions are down, up, and down. The LED remains off at all times.

LED Mode: ON (LED, Sensor, and PB Enabled) Switch positions are factory set up, down, and up. The controller determines the LED mode.

LED Mode: NO PB (LED and PB Disabled, but Sensor Enabled) Switch positions are all down. LED is off, and the PB does not function.

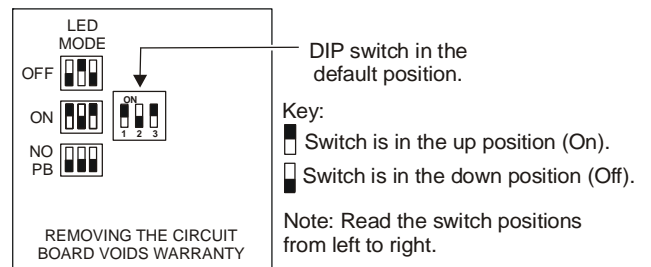

Figure 5: DIP Switch Positions

Table 3: Controller Compatibility with LED Mode and PB

Types of TE-6800	LED Mode (Figure 5)	Features Enabled on TE-6800	Features Recognized by Controller				
			AHU	UNT1100	VAV1xx or UNT1xx	VMA1200 Series ¹	VMA1400 Series ¹
Warmer/Cooler Setpoint	LED Off ²	Sensor and Manual Override	No	Yes	Yes	Yes	Yes
	LED On	Sensor, Manual Override, and LED	No	No	No	Yes	Yes
	No PB	Room Sensor Only	Yes	Yes	Yes	Yes	Yes

- For these controllers, the LED appears brighter when the manual override PB is pushed.
- Holding the manual Override PB for more than 2 seconds may affect the sensor reading.

Temperature Setpoint

Adjust the setpoint using the setpoint adjustment dial. Rotate clockwise to raise the temperature. Rotate counterclockwise to lower the temperature.

Troubleshooting

TE-6800 Series Temperature Sensors are recommended for use only with Johnson Controls® digital controllers. If the TE-6800 is not functioning properly, use the following procedure to identify the problem and determine a solution:

1. Check that the TE-6800 is mounted in a location indicative of the space temperature (for example, away from drafts or sunlight).
2. Check the wiring:
 - Verify that the wiring is correct. The modular jack connector must be inserted with the proper polarity (not reversed). Misalignment can cause damage.
 - Check all supply voltage connections. See Figure 2, Figure 3, or Figure 4, if necessary.
3. Check the settings:
 - Verify that any scaling modifications, setpoint adjustments, and overrides have been saved and downloaded to the controller.
 - Check the override status (Temporary Occupancy mode vs. Unoccupied mode) at the controller.
 - Check the setpoint settings.
4. Confirm DIP switch positions if:
 - the LED remains on or is dim
 - the room sensor reading is outside of the normal range for the space being sensed

Note: Make sure the DIP switch setting is correct for the controller used with the TE-6800.

5. Replace the TE-6800 if the troubleshooting suggestions fail to remedy the problem.

Repair Information

Do not field repair the TE-6800 temperature sensors. As with any electrical device, keep the air vents clean and free from dust or obstruction. If the TE-6800 temperature sensor fails to operate within its specifications, replace the unit. For a replacement sensor, contact the nearest Johnson Controls representative.

Technical Specifications

TE-6800 Series Temperature Sensors

Nickel Sensor	Temperature Sensor	1000 ohm thin-film nickel
	Temperature Coefficient	Approximately 3 ohms per F° (5.4 ohms per C°)
	Reference Resistance	1000 ohms at 70°F (21°C)
	Accuracy	±0.34F° at 70°F (±0.18C° at 21°C)
Platinum Sensor	Temperature Sensor	1000 ohm thin-film platinum
	Temperature Coefficient	Approximately 2 ohms per F° (3.9 ohms per C°)
	Reference Resistance	1000 ohms at 32°F (0°C)
	Accuracy	±0.35F° at 70°F (±0.19C° at 21°C)
Setpoint Range	Single Adjustment	Warmer/cooler
Sensor Response Time	10 minutes at 10 feet per minute	
Field Connections	Modular Jack	8-position modular jack connector
	Terminal Block	Screw type terminals for 18 to 24 AWG wire
Zone Bus Access	6-pin connector with front bottom access for a laptop with HVAC PRO software and CVTPRO converter	
Manual Override	Integral momentary push button (DIP switch selectable)	
LED Light	Green LED light indicates two modes of operation (VMA1200 and VMA1400 Series controllers only)	
Ambient Operating Conditions	32 to 131°F (0 to 55°C) 10 to 95% RH, noncondensing; 86°F (30°C) maximum dew point	
Ambient Storage Conditions	-40 to 140°F (-40 to 60°C) 5 to 95% RH, noncondensing; 86°F (30°C) maximum dew point	
Materials	White thermoplastic	
Accessory	NS-WALLPLATE-0	Adapts a TE-6800 Sensor (80 x 80 mm) to a standard 80 x 120 mm wallbox
Dimensions (H x W x D)	3-1/4 x 3-1/4 x 1-7/16 in. (80 x 80 x 36 mm)	
Shipping Weight	1 lb (0.5 kg)	
Compliance 	United States	UL Listed, File E107041, CCN PAZX, Under UL 916, Energy Management Equipment
	Canada	UL Listed, File E107041, CCN PAZX7, Under CAN/CSA C22.2 No. 205, Signal Equipment
	Europe	CE Mark – Johnson Controls, Inc. declares that the TE-6800 Series Temperature Sensors are in compliance with the essential requirements and other relevant provisions of the EMC Directive 2004/108/EC
	Australia and New Zealand	C-Tick Mark, Australia/NZ Emissions Compliant



Building Efficiency

507 E. Michigan Street, Milwaukee, WI 53202

Metasys® and Johnson Controls® are registered trademarks of Johnson Controls, Inc. All other marks herein are the marks of their respective owners. © 2010 Johnson Controls, Inc.